

HECLM SERIES FORCED DRAFT WATER BOILERS
(HECLM90-HECLM300) REVERSE CONSTRUCTION

EFFECTIVE DATE: 4/7/14
REPLACES: 6/10/14

NOTES:

1. ALL DIMENSIONS ARE IN INCHES. THOSE IN PARENTHESES ARE CENTIMETERS.
2. LOCATION DIMENSIONS ARE ALL $\pm 1/2"$.
3. GAS TRAIN, CONTROL AND BURNER CONFIGURATION WILL VARY DEPENDING ON JOB SPECIFICATIONS & CONDITIONS.
4. DIMENSIONS ARE SUBJECT TO CHANGE WITHOUT NOTICE. CONSULT FACTORY FOR CERTIFIED DIMENSIONS.

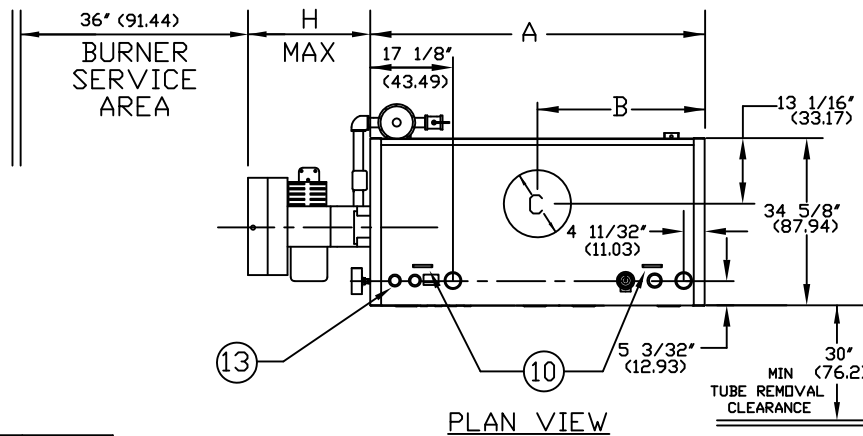

MODEL	K
90-240	12"
270-300	15"

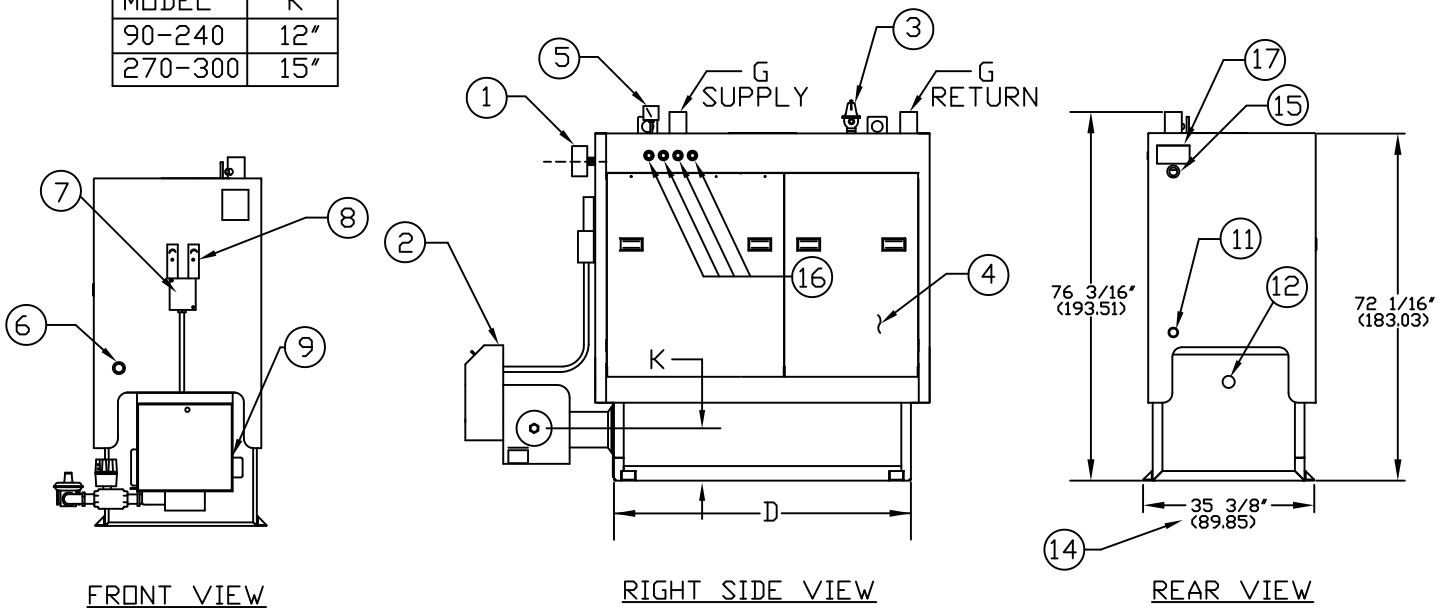

1. PROBE TYPE L.W.C.D.	6. CLNDOUT./INSP. OPNG-1 1/2"NPT	11. DRAIN CONNECTION	16. CONTROL CONNECTIONS
2. FORCED DRAFT BURNER	7. ELEC. ENCLOSURE	12. FLAME OBSERVATION PORT	17. ASME NAME PLATE
3. RELIEF VALVE	8. AQUASTATS	13. 1" (2.54) EXP TANK CONN	
4. TUBE ACCESS PANEL	9. OIL PUMP LOCATION	14. WIDTH OVER MTG BASE	
5. PRESS./TEMP. GAUGE	10. LIFTING LUG	15. CLNDOUT./INSP. OPNG-1 1/4"NPT	

BOILER MODEL	HECLM90	HECLM120	HECLM150	HECLM180	HECLM210	HECLM240	HECLM270	HECLM300
A-LENGTH OVER JACKET	41 7/16" (105.24)	50 11/16" (128.74)	59 11/16" (151.60)	69 1/8" (175.57)	78 3/8" (199.07)	88" (223.52)	97" (246.38)	106 5/8" (270.82)
B-FLUE LOCATION	20 11/16" (52.54)	25 5/16" (64.29)	29 13/16" (75.72)	34 9/16" (87.78)	39 3/16" (99.53)	44" (111.76)	48 1/2" (123.19)	53 5/16" (135.41)
C-FLUE DIAMETER	10" (25.40)	10" (25.40)	12" (30.48)	14" (35.56)	14" (35.56)	16" (40.64)	16" (40.64)	16" (40.64)
D-LENGTH OVER BASE	33 7/8" (86.04)	43 1/8" (109.53)	52 3/8" (133.03)	61 5/8" (156.52)	70 7/8" (180.02)	80 1/8" (203.51)	89 7/16" (219.54)	99 1/16" (251.61)
G-SUPPLY/ RETURN NOZZLE SIZE	3" (7.62)	3" (7.62)	3" (7.62)	3" (7.62)	3" (7.62)	3" (7.62)	3" (7.62)	3" (7.62)

H-BURNER EXTENSION CONSULT FACTORY FOR BURNER EXTENSION APPLICATIONS



BRYAN BOILERS

783 NORTH CHILI AVE
PERU, INDIANA 46970

ORDER NO. _____
ORDER REV. NO. _____
FORM NO. 2188

HECLM SERIES FORCED DRAFT WATER BOILER REVERSE CONSTRUCTION

BOILER MODEL		HECLM90	HECLM120	HECLM150	HECLM180	HECLM210	HECLM240	HECLM270	HECLM300
INPUT	MBH	900	1,200	1,500	1,800	2,100	2,400	2,700	3,000
	(KW)	263.7	351.6	439.5	527.4	615.3	703.2	791.1	879.0
OUTPUT*	MBH	765.0	1,020.0	1,275.0	1,530.0	1,785.0	2,040.0	2,295.0	2,550.0
	(KW)	224.1	298.9	373.6	448.3	523.0	597.7	672.4	747.1
BOILER HORSEPOWER*	HP	23	30	38	46	53	61	69	76
	(KW)	225	294	372	451	519	598	676	745
TUBE DIAMETER	INCHES	1.00	1.00	1.00	1.00	1.00	1.00	1.00	1.00
	(CM)	2.54	2.54	2.54	2.54	2.54	2.54	2.54	2.54
NUMBER OF TUBES		27	36	45	54	63	72	81	90
PRESSURE VESSEL									
VOLUME	GAL	34	43	53	63	72	81	91	101
	(L)	128.7	162.8	201.6	236.6	271.6	306.6	345.4	380.4
HEATING SURFACE	SQ FT	171	227	282	338	394	451	506	564
	(SQ M)	15.9	21.1	26.2	31.4	36.6	41.9	47.0	52.4
OPERATING WEIGHT	LBS	2,394	2,759	3,304	3,721	4,338	4,876	5,501	6,014
	(KG)	1,085.7	1,251.4	1,498.7	1,688.1	1,967.9	2,211.7	2,495.3	2,727.8
SHIPPING WEIGHT	LBS	2,110	2,400	2,860	3,200	3,740	4,200	4,740	5,175
	(KG)	957.1	1,088.7	1,297.3	1,451.6	1,696.5	1,905.3	2,150.1	2,347.6

* Output and Boiler HP based on an average natural gas combustion efficiency.